



Auto 100  
Auto 125  
Auto 150

**Use**

- Extract fans

**Application**

- Residential premises
- Flats, cottages
- Offices
- Utility spaces
- Trade premises
- Restaurants
- Health care facilities
- Child care facilities

**Features**

- Wall mounting
- Easy maintenance
- Continuous operation
- Automatic shutters
- Ball bearing motor
- 5 year warranty

**Options**

*Pull-cord switch*

Pull-cord switch

*Timer*

- Turn-off delay adjustable from 2 to 30 min

*Humidity sensor*

- Humidity setpoint adjustable from 60 % up to 90 %.
- Turn-off delay adjustable from 2 to 30 min

*Motion sensor*

- Detection range from 1 up to 4 m.
- Detection angle up to 100°.
- Turn-off delay adjustable from 2 to 30 min.

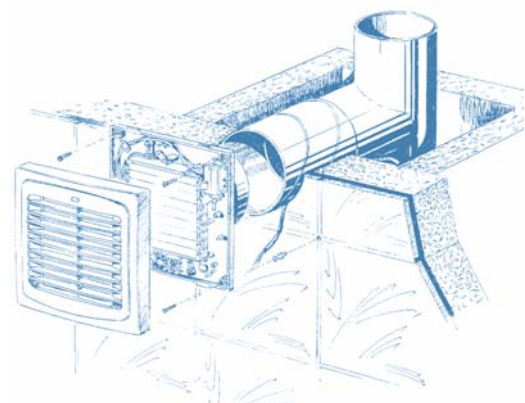

Model	Pull-cord switch	Turn-off delay timer	Humidity sensor	Motion sensor
Auto 100				
100 S	●			
100 T		●		
100 ST	●	●		
100 H		●	●	
100 SH	●	●	●	
100 IR		●		○
Auto 125				
125 S	●			
125 T		●		
125 ST	●	●		
125 H		●	●	
125 SH	●	●	●	
125 IR		●		○
Auto 150				
150 S	●			
150 T		●		
150 ST	●	●		
150 H		●	●	
150 SH	●	●	●	
150 IR		●		○

**Overall and mounting dimensions**

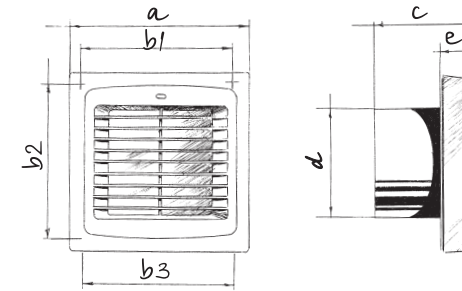

Model	Dimensions [mm]						
	a	b1	b2	b3	c	d	e
Auto 100	166	150	150	150	90	100	30
Auto 125	186	128	173	174	98	125	33
Auto 150	210	150	195	196	115	150	34

**Technical data**

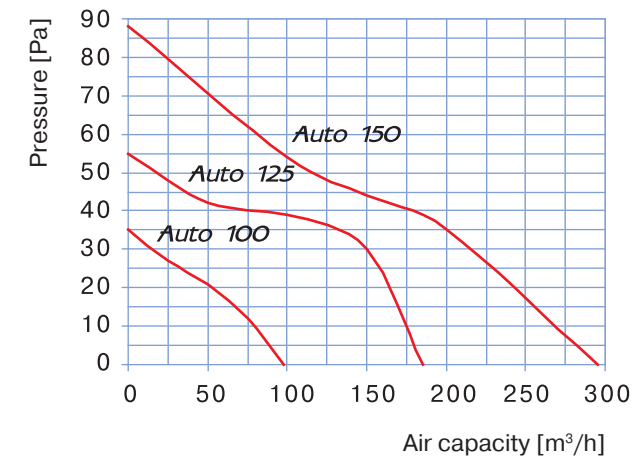

Parameters	Auto 100	Auto 125	Auto 150
Voltage [V]	220-240	220-240	220-240
Power [W]	18	22	26
Air capacity [m³/h]	98	185	295
Sound pressure level at 3 m [dB(A)]	34	35	39
RPM [min <sup>-1</sup> ]	2300	2400	2400



**Packing**

