



Centrifugal fans for rectangular ducts

Box-F

Air capacity – up to 9540 m³/h



Use

- Supply and exhaust ventilation systems installed in various premises.
- Compatible with 400x200 up to 1000x500 mm rectangular air ducts.

Design

- Atmospheric resistant galvanized steel casing and impeller.
- The fan is rated for continuous operation.
- Fitted with standard 20 mm connecting flanges for connection to rectangular air ducts.
- Access cover on the casing for inspection and maintenance operations.
- The fans with standard size from 40x20 up to 60x35 are equipped with a terminal block integrated into the casing with leaded outside sealed electrical lead-in for connection to power mains.
- The fans with standard size from 70x40 up to 100x50 are equipped with an external terminal block for connection to power mains.

Motor

- Four- or six-pole asynchronous motor with external rotor and centrifugal impeller with forward curved blades.
- Due to its turbine design the fan has excellent air dynamic characteristics (high performance and pressure drop).
- Single-phase (**E**) or three-phase (**D**) motor modifications.
- Equipped with ball bearings for longer service life.
- Dynamically balanced turbine.
- Overheating protection by built-in thermal switches with leaded outside terminals for connection to external protecting controls.

- The thermal switch terminal leads are designed for connection to respective circuit of the overload relay or respective terminals of the autotransformer or thyristor speed controller.

Speed control

- Smooth speed control with an external thyristor controller or step speed control with an external auto transformer (both available upon separate order).

Mounting

- The fan is designed for mounting inside rectangular air ducts and can be installed in any position.
- The fan flanges are connected to the air ducts through the bolts inserted into the flange holes.
- Mounting to a round air duct on exhaust flange through a round pipe reducer. Available upon order.
- If flexible vibration-absorbing connectors are used to connect the fan to the air ducts provide their fixation to mounting structures with supports or brackets.
- While mounting provide enough space for accessing the cover for service operations.

ErP data	
Overall efficiency	η , (%)
Measurement category	MC
Efficiency category	EC
Efficiency grade	N
Variable speed drive	VSD
Power	[kW]
Current	[A]
Air flow	[m ³ /h]
Static pressure	[Pa]
Speed	[n/min ⁻¹]
Specific ratio	SR

Overall dimensions

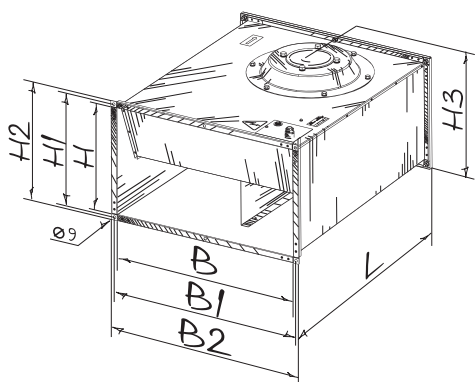

Type	Dimensions [mm]								Weight [kg]
	B	B1	B2	H	H1	H2	H3	L	
Box-F 40x20 4E	400	420	440	200	220	240	255	500	17.5
Box-F 40x20 4D	400	420	440	200	220	240	255	500	17.5
Box-F 50x25 4E	500	520	540	250	270	290	335	640	24.0
Box-F 50x25 4D	500	520	540	250	270	290	335	640	24.0
Box-F 50x30 4E	500	520	540	300	320	340	365	680	33.0
Box-F 50x30 4D	500	520	540	300	320	340	365	680	33.0
Box-F 60x30 4E	600	620	640	300	320	340	375	680	35.0
Box-F 60x30 4D	600	620	640	300	320	340	375	680	35.0
Box-F 60x35 4E	600	620	640	350	370	390	425	735	49.5
Box-F 60x35 4D	600	620	640	350	370	390	425	735	49.5
Box-F 70x40 4D	700	720	740	400	420	440	480	780	60.0
Box-F 80x50 6D	800	820	840	500	520	540	580	820	70.0
Box-F 80x50 4D	800	820	840	500	520	540	580	820	74.0
Box-F 90x50 6D	900	920	940	500	520	540	580	954	90.0
Box-F 100x50 6D	1000	1020	1040	500	520	540	580	954	95.0

Specifications

Parameters	Box-F 40x20 4E	Box-F 40x20 4D	Box-F 50x25 4E	Box-F 50x25 4D	Box-F 50x30 4E	Box-F 50x30 4D	Box-F 60x30 4E
Voltage [V / 50 Hz]	230	400	230	400	230	400	230
Power [W]	295	282	535	570	710	855	1240
Current [A]	1.32	0.60	2.49	0.94	3.10	1.70	6.45
Maximum air capacity [m³/h]	1440	1470	1750	1850	2350	2350	2950
RPM [min ⁻¹]	1350	1300	1250	1270	1230	1300	1210
Sound pressure level at 3 m distance [dBA]	50	52	53	54	57	56	59
Max. operating temperature [°C]	-25 +40	-25 +45	-20 +40	-20 +40	-25 +70	-20 +50	-25 +50
Ingress protection rating	IPX4	IPX4	IPX4	IPX4	IPX4	IPX4	IPX4

Parameters	Box-F 60x30 4D	Box-F 60x35 4E	Box-F 60x35 4D	Box-F 70x40 4D	Box-F 80x50 6D	Box-F 80x50 4D	Box-F 90x50 6D	Box-F 100x50 6D
Voltage [V / 50 Hz]	400	230	400	400	400	400	400	400
Power [W]	1560	2840	2460	3630	2790	5850	3870	3870
Current [A]	2.73	13.90	3.93	6.00	5.18	9.35	7.0	7.0
Maximum air capacity [m³/h]	3740	4260	5020	6450	7610	8120	9540	9540
RPM [min ⁻¹]	1310	1260	1300	1320	830	1140	930	930
Sound pressure level at 3 m distance [dBA]	57	59	60	65	59	67	61	61
Max. operating temperature [°C]	-25 +65	-20 +40	-20 +40	-25 +40	-20 +50	-25 +40	-20 +55	-20 +55
Ingress protection rating	IPX4	IPX4	IPX4	IPX4	IPX4	IPX4	IPX4	IPX4

Specifications

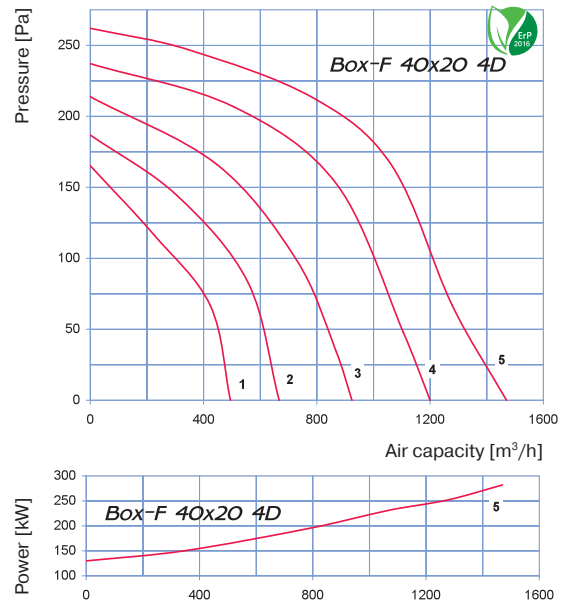
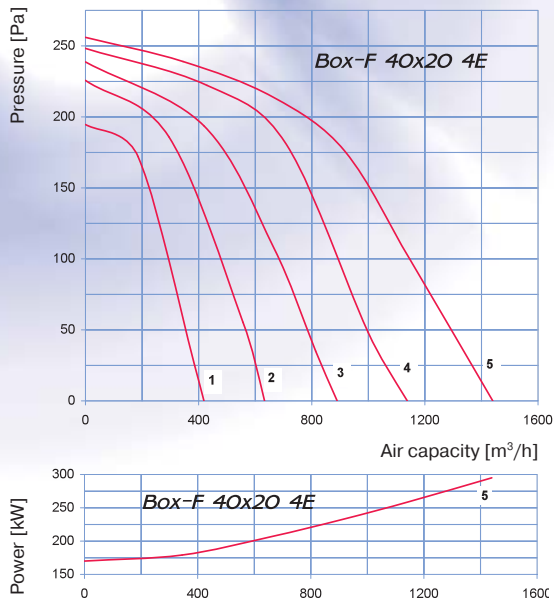

Sound-power level	Octave-frequency band [Hz]								
	Gen	63	125	250	500	1000	2000	4000	8000
L _{WA} to inlet, [dBA]	69	58	68	63	59	56	53	53	45
L _{WA} to outlet, [dBA]	70	53	63	67	62	65	63	58	55
L _{WA} to environment, [dBA]	59	34	46	57	52	49	43	40	36

Sound-power level	Octave-frequency band [Hz]								
	Gen	63	125	250	500	1000	2000	4000	8000
L _{WA} to inlet, [dBA]	72	56	69	65	57	58	57	53	48
L _{WA} to outlet, [dBA]	74	54	65	66	61	63	60	61	55
L _{WA} to environment, [dBA]	61	34	44	56	52	50	44	40	33

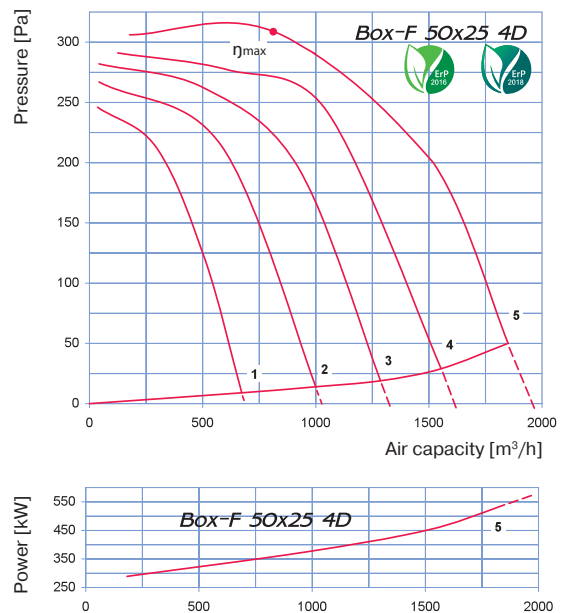
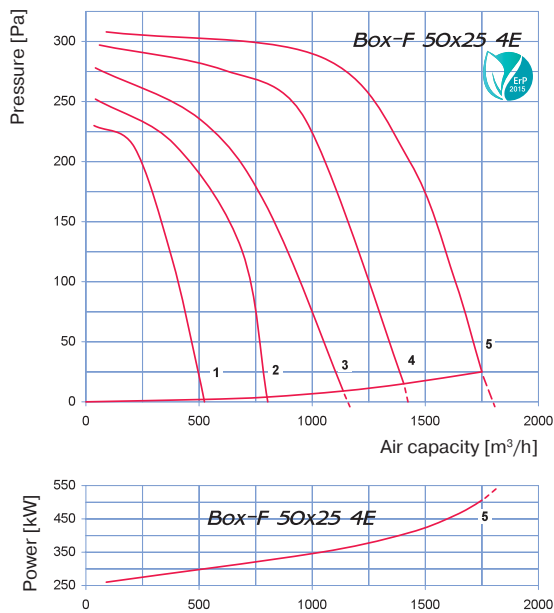

Sound-power level	Octave-frequency band [Hz]								
	Gen	63	125	250	500	1000	2000	4000	8000
L _{WA} to inlet, [dBA]	72	58	67	62	57	62	64	62	60
L _{WA} to outlet, [dBA]	77	57	63	62	66	72	69	68	63
L _{WA} to environment, [dBA]	62	41	49	54	53	56	52	51	53

Sound-power level	Octave-frequency band [Hz]								
	Gen	63	125	250	500	1000	2000	4000	8000
L _{WA} to inlet, [dBA]	74	60	67	64	61	64	62	60	58
L _{WA} to outlet, [dBA]	76	57	65	65	67	69	69	68	63
L _{WA} to environment, [dBA]	61	41	48	53	53	56	52	50	53

η _s (%)	MC	EC	N	VSD	[kW]	[A]	[m³/h]	[Pa]	[RPM]	SR
34.3	A	Static	44.9	Yes	0.210	0.6	820	310	1420	1

Specifications

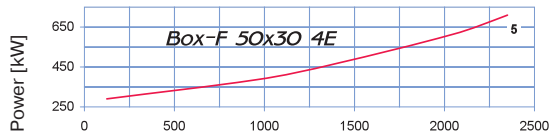
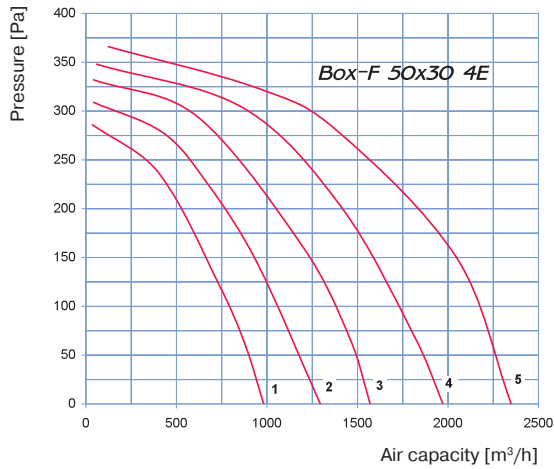

Sound-power level	Gen	Octave-frequency band [Hz]							
		63	125	250	500	1000	2000	4000	8000
L_{wA} to inlet, [dBA]	74	64	69	65	63	66	67	65	60
L_{wA} to outlet, [dBA]	79	62	69	66	72	73	72	71	64
L_{wA} to environment, [dBA]	64	46	53	59	54	58	56	49	50

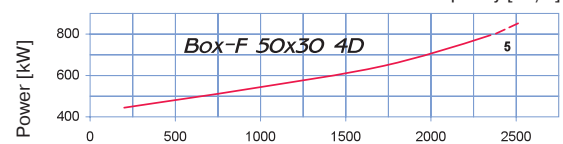
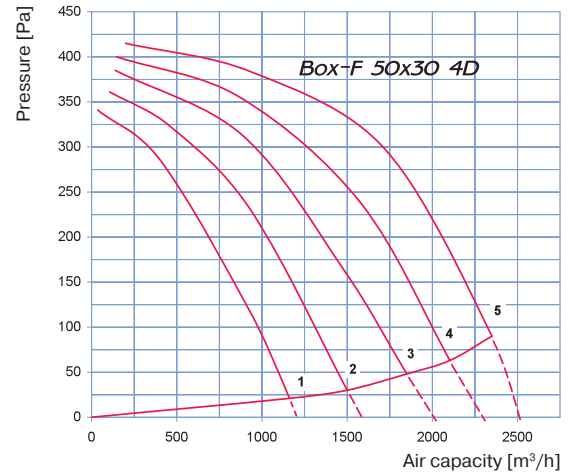

Sound-power level	Gen	Octave-frequency band [Hz]							
		63	125	250	500	1000	2000	4000	8000
L_{wA} to inlet, [dBA]	77	67	69	62	63	68	68	68	63
L_{wA} to outlet, [dBA]	79	61	68	69	71	75	74	73	68
L_{wA} to environment, [dBA]	65	46	55	58	56	60	54	48	47

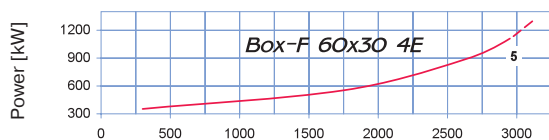
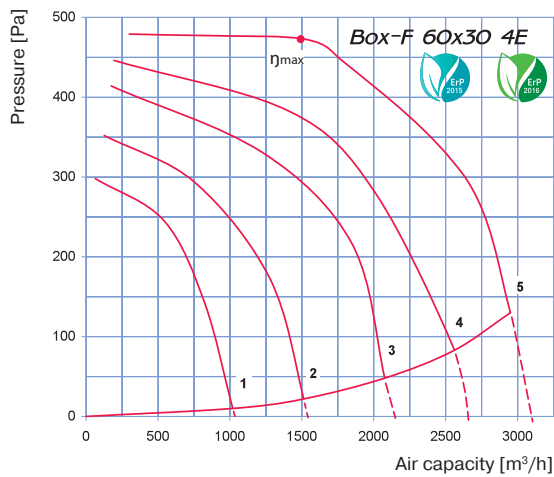

Sound-power level	Gen	Octave-frequency band [Hz]							
		63	125	250	500	1000	2000	4000	8000
L_{wA} to inlet, [dBA]	83	66	77	69	66	71	70	71	67
L_{wA} to outlet, [dBA]	85	62	77	71	74	79	76	73	67
L_{wA} to environment, [dBA]	69	42	65	66	61	61	56	53	47

η_v (%)	MC	EC	N	VSD	[kW]	[A]	[m³/h]	[Pa]	[RPM]	SR
35.8	A	Static	43.7	No	0.555	2.33	1482	473	1425	1

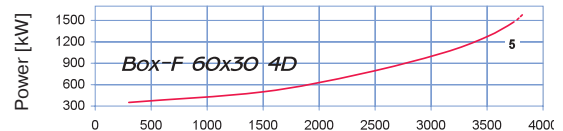
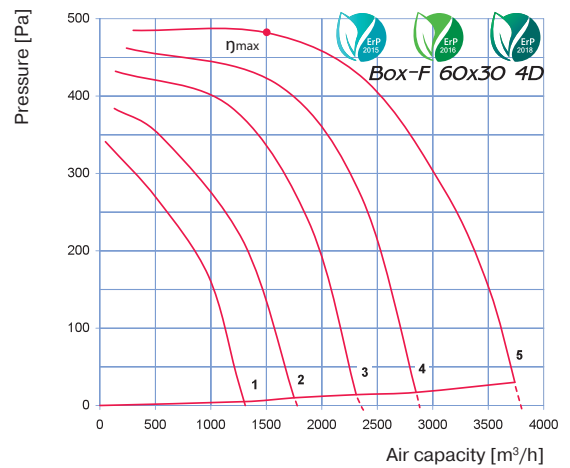

Sound-power level	Gen	Octave-frequency band [Hz]							
		63	125	250	500	1000	2000	4000	8000
L_{wA} to inlet, [dBA]	82	66	77	67	67	70	72	68	69
L_{wA} to outlet, [dBA]	82	62	77	71	76	79	75	76	67
L_{wA} to environment, [dBA]	71	43	63	62	64	62	55	49	51

η_v (%)	MC	EC	N	VSD	[kW]	[A]	[m³/h]	[Pa]	[RPM]	SR
40.6	A	Static	48.8	No	0.510	1.9	1508	485	1440	1

Specifications

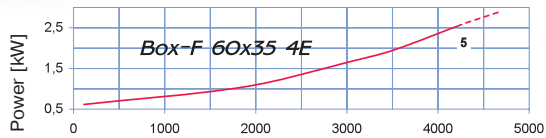
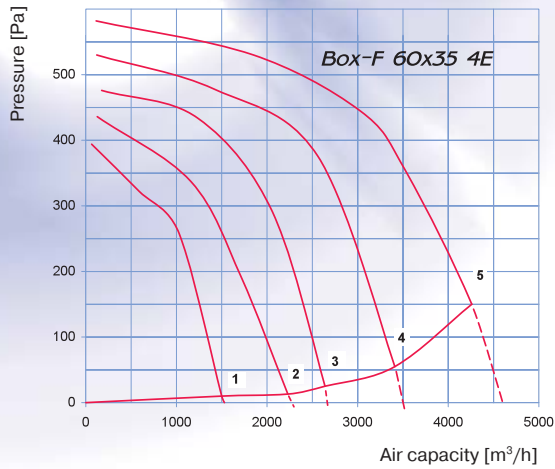

Sound-power level	Gen	Octave-frequency band [Hz]							
		63	125	250	500	1000	2000	4000	8000
L _{WA} to inlet, [dBA]	78	71	74	65	66	75	72	70	64
L _{WA} to outlet, [dBA]	86	69	73	74	74	78	76	77	68
L _{WA} to environment, [dBA]	67	54	60	63	58	62	55	51	48

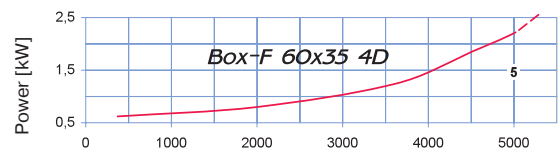
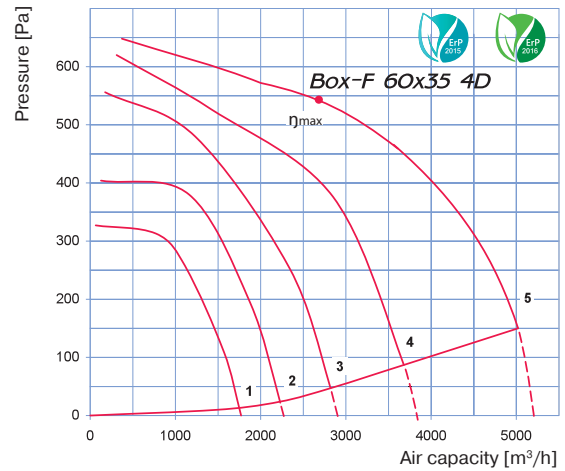

Sound-power level	Gen	Octave-frequency band [Hz]							
		63	125	250	500	1000	2000	4000	8000
L _{WA} to inlet, [dBA]	80	72	75	69	67	73	71	69	67
L _{WA} to outlet, [dBA]	84	66	74	70	76	79	76	74	68
L _{WA} to environment, [dBA]	68	52	62	65	61	58	56	52	48

η, (%)	MC	EC	N	VSD	[kW]	[A]	[m³/h]	[Pa]	[RPM]	SR
36.9	A	Static	43	No	1.120	2.56	2693	542	1410	1

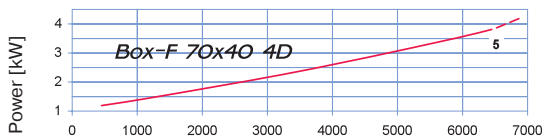
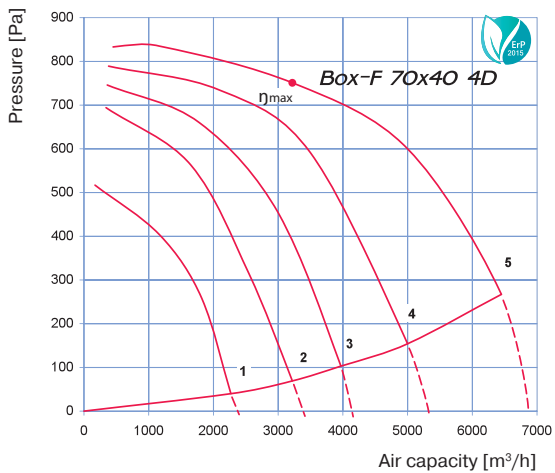

Sound-power level	Gen	Octave-frequency band [Hz]							
		63	125	250	500	1000	2000	4000	8000
L _{WA} to inlet, [dBA]	82	80	77	70	71	75	73	71	68
L _{WA} to outlet, [dBA]	86	74	77	75	78	83	81	77	71
L _{WA} to environment, [dBA]	71	55	64	69	67	70	63	62	59

η, (%)	MC	EC	N	VSD	[kW]	[A]	[m³/h]	[Pa]	[RPM]	SR
32.4	A	Static	41	No	1.890	4.34	3240	751	1430	1

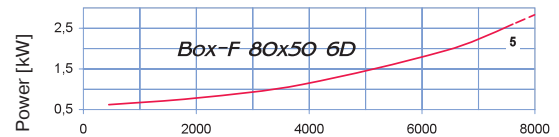
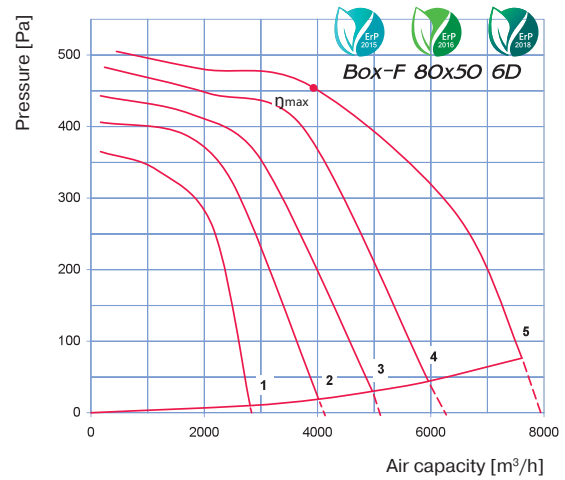

Sound-power level	Gen	Octave-frequency band [Hz]							
		63	125	250	500	1000	2000	4000	8000
L _{WA} to inlet, [dBA]	77	64	66	66	70	71	70	66	62
L _{WA} to outlet, [dBA]	82	64	66	69	76	74	73	73	64
L _{WA} to environment, [dBA]	64	51	59	58	61	60	55	50	49

η, (%)	MC	EC	N	VSD	[kW]	[A]	[m³/h]	[Pa]	[RPM]	SR
43.6	A	Static	49.5	No	1.150	2.9	3870	457	940	1

Specifications

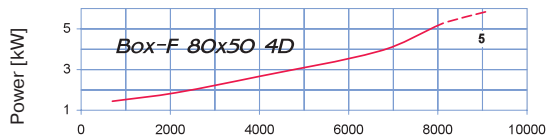
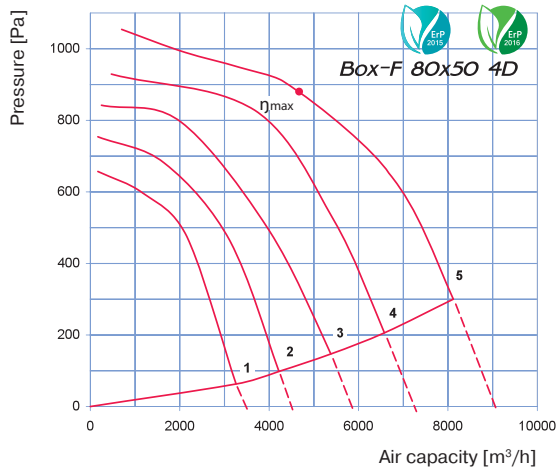

Sound-power level	Octave-frequency band [Hz]								
	Gen	63	125	250	500	1000	2000	4000	8000
L _{wA} to inlet, [dBA]	82	71	74	75	70	75	75	70	67
L _{wA} to outlet, [dBA]	90	72	77	76	82	86	85	80	78
L _{wA} to environment, [dBA]	73	61	68	67	65	70	66	61	60

η, (%)	MC	EC	N	VSD	[kW]	[A]	[m³/h]	[Pa]	[RPM]	SR
42.3	A	Static	45.9	No	2.743	4.9	4648	881	1330	1

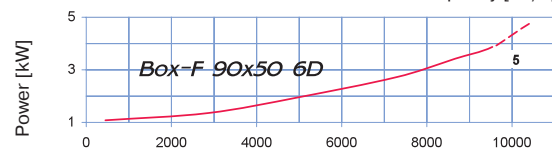
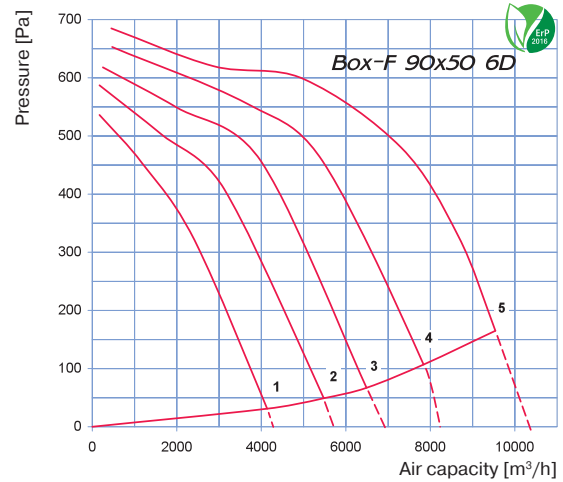

Sound-power level	Octave-frequency band [Hz]								
	Gen	63	125	250	500	1000	2000	4000	8000
L _{wA} to inlet, [dBA]	78	70	68	63	72	69	71	68	64
L _{wA} to outlet, [dBA]	83	71	70	70	80	78	79	74	68
L _{wA} to environment, [dBA]	65	56	64	60	63	58	56	52	51

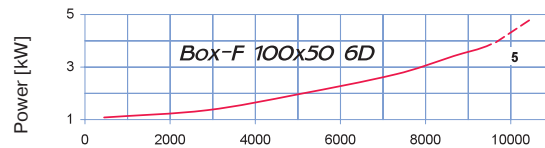
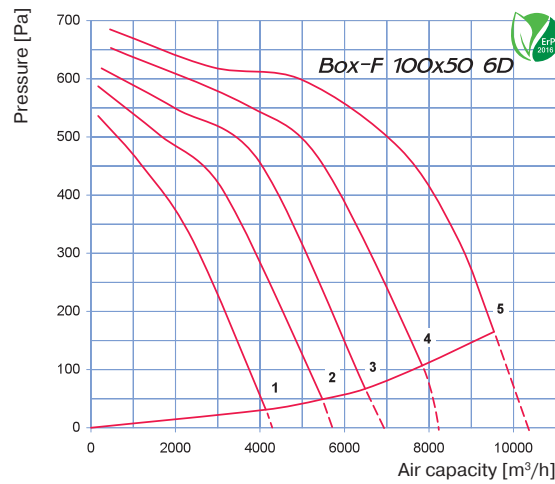

Sound-power level	Octave-frequency band [Hz]								
	Gen	63	125	250	500	1000	2000	4000	8000
L _{wA} to inlet, [dBA]	80	73	68	64	74	71	72	69	66
L _{wA} to outlet, [dBA]	86	70	71	71	78	78	78	75	71
L _{wA} to environment, [dBA]	69	59	61	59	65	61	58	53	53